

## INSTRUCTION MANUAL

# **CASE AF10 / AF20**

### WARNING:

Read this instruction manual carefully before using the product



Thank you for choosing a PROIETTA product

# INDEX

1) SAFETY INFORMATION	1
2) MODELS	2
3) VENTILATION SYSTEM	4
4) USAGE INSTRUCTIONS	5
4.1) CASE TILT ADJUSTMENT	5
4.2) HANGING INSTALLATION	5
4.3) INSTALLATION IN PORTRAIT FORMAT	5
4.4) POWER CONNECTION	6
4.5) FIXING THE VIDEO PROJECTOR	7
5) MAINTENANCE	8
6) CAUSE AND SOLUTIONS OF POSSIBLE PROBLEMS	9
7) PROIETTA APP INSTALLATION	10
8) PROIETTA CONTROL BOARD (LED SIGNALLING OPERATION)	13
9) WARRANTY	15
10) DECLARATION OF CONFORMITY	16
11) DISPOSAL OF UNUSED PRODUCT	16

# SAFETY INFORMATION



Read the following security information carefully before performing any operations. The product described in this manual is an outdoor protective case for video projectors. Any other use is not provided by the manufacturer and therefore relieves him of any liability for damages arising from misuse.

Be sure to securely attach the protective case to an architectural element that ensures its stability and reliability. All elements used for installation (screws, bolts, brackets, etc.) must always be adjusted to the load they need to support.

Use an M12 bolt with a self-locking nut and use a security chain in the event of a suspended installation.

**The protective case should always be connected to the power supply** even when the video projector inside is turned off. This ensures constant ventilation during hot days or maintaining a warmer temperature on cold days, ensuring that the projector works properly.

For proper use, before using the protective case, read carefully the instruction manual of the video projector that you plan to install inside. The minimum temperature sustained by the protective case is  $-25^{\circ}\text{C}$ . The maximum temperature supported is  $5^{\circ}\text{C}$  lower than the maximum operating temperature shown in your projector's instruction manual.

e.g. A video projector with an operating temperature from  $0^{\circ}\text{C}$  to  $45^{\circ}\text{C}$  → operating temperature insured by the protective case: from  $-25^{\circ}\text{C}$  to  $40^{\circ}\text{C}$ .

Do not place objects on the power cable and in case of damage to the manufacturer for replacement in order to avoid dangers of electrocution.

The only maintenance operation allowed in warranty is the replacement of the filters. Any other repairs must be carried out solely by the manufacturer, who denies any responsibility for unauthorized interventions.

Air intakes should never be covered or clogged with any material. Be sure to provide adequate ventilation to the case to protect it from overheating. The protective case should not be placed in a closed installation or in a compartment that is too small and without enough ventilation.

Never touch the protective case and all its components with wet hands.

Never place the protective case on flammable and/or combustible surfaces.

# MODELS

## AF10

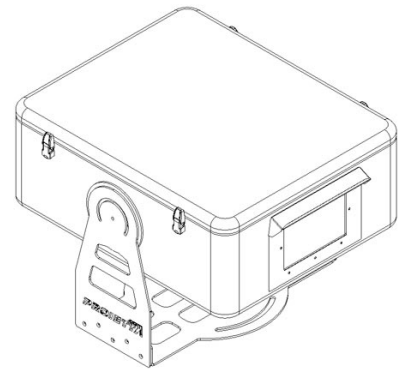
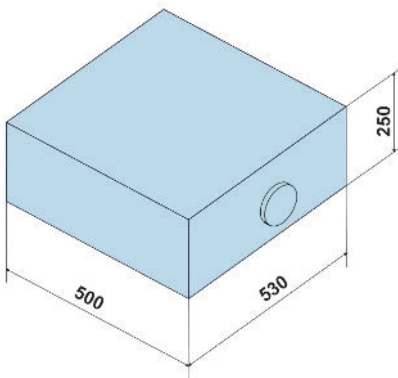
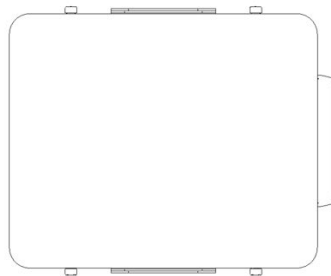
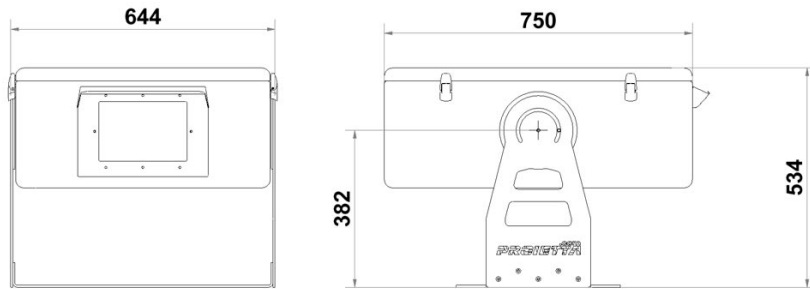

**Maximum dimensions of the video projector insertable in the CASE AF10**

## AF20

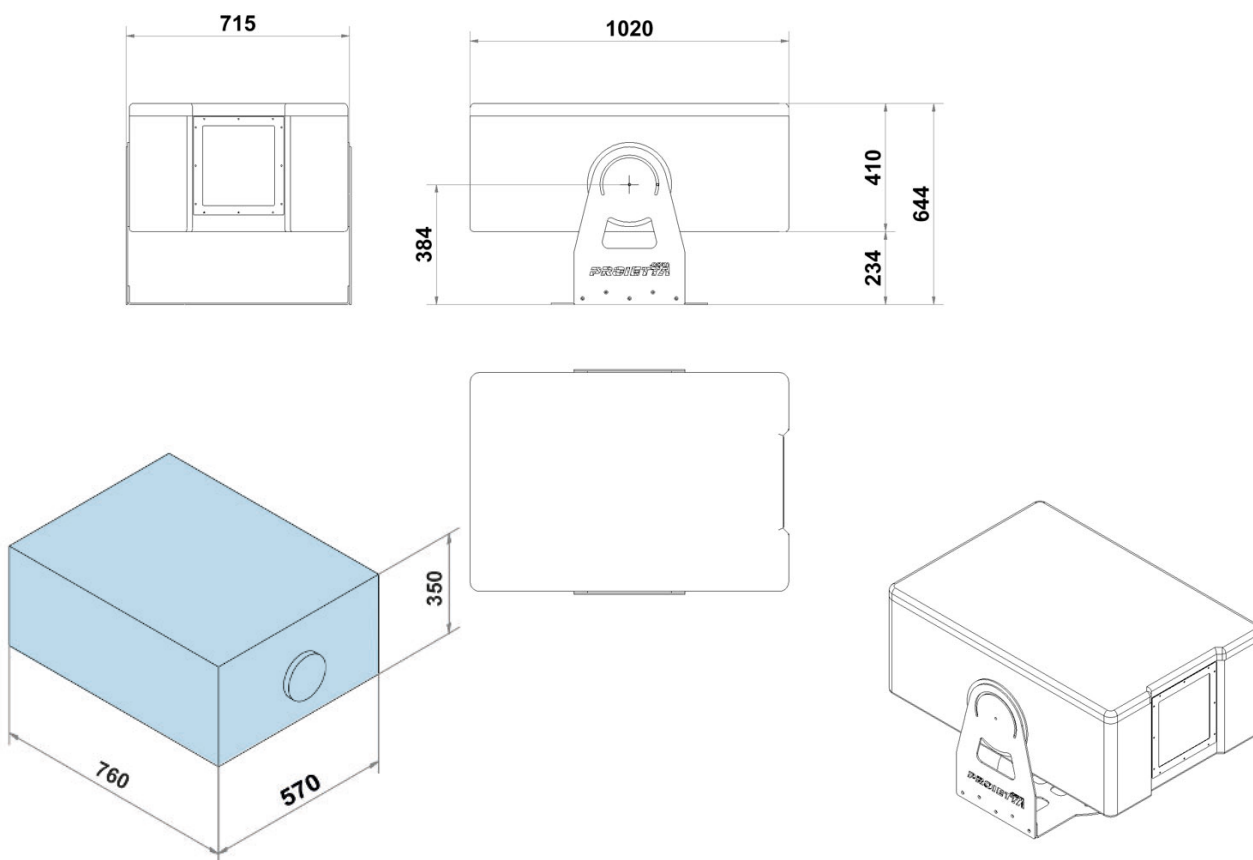

**Maximum dimensions of the video projector insertable in the CASE AF20**

Do not insert a bigger projector video than the measurements indicated for each type of protective case. Choosing an undersized case, compared to the video projector placed inside, can result in insufficient ventilation and irreversible damage to the device itself.

# VENTILATION SYSTEM

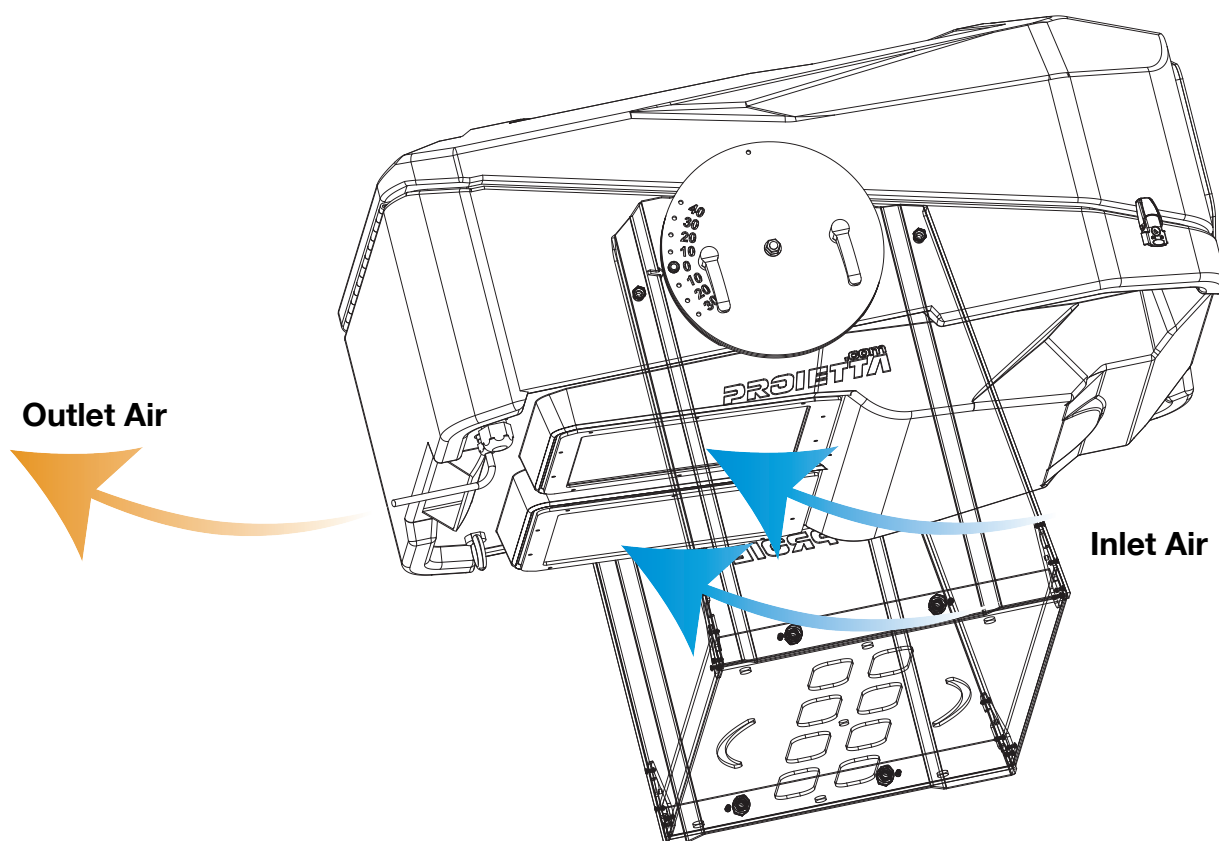

The air enters in the case at outdoor ambient temperature ( $T_{\text{INLET AIR}}$ ) from the filter-equipped air intakes located at the bottom of the case (there is only one air intake for the AF6 model).

The temperature inside the protective case is measured by a probe that:

- when the temperature rises above a certain value drives the fan;
- when the temperature drops below a certain value drives the heating system.

The air enters in the case at outdoor ambient temperature, it's mixed with the temperature inside  $T_1$  and is finally ejected on the back of the case at temperature  $T_2$  ( $T_2 > T_1$ ).

The rear fan of the protective case is necessary to extract the hot air emitted by the projector. The fan on the front of the protective case (in the bottom) is to inject air to cool it down. Only AF32 and AF40 models have this fan, in the AF6, AF10, AF20 the air is automatically sucked inside the case by the internal ventilation system.



Air intakes should never be covered or clogged with any material. Be sure to provide adequate ventilation to the case to protect it from overheating. The protective case should not be placed in a closed installation or in a compartment that is too small and without enough ventilation.

# USAGE INSTRUCTION

## CASE TILT ADJUSTMENT

Adjust the inclination of the protective case according to the instructions of the manual of use of the installed projector video.

The case can be tilted no more than 20 degrees up or 20 degrees down relative to the horizontal plane. Contact Proietta Support in case you need to tilt it more.

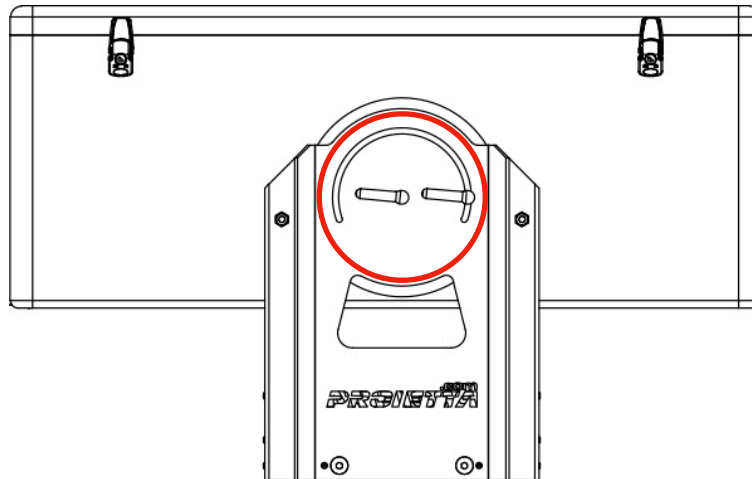

## HANGING INSTALLATION

The protective case must always be installed with filters facing the ground; it doesn't have to be installed upside down.

Even in this type of installation the case can be tilted no more than the measures written on "Case Tilt Adjustment" paragraph.

## INSTALLATION IN PORTRAIT FORMAT

It is not possible to install the protective case sideways.

Contact Proietta Support for installations that require vertical positioning (portrait format) of the video projector.

## POWER CONNECTION

Connect your case to the current according to the security rules currently in force in your country/region.

The supply voltage must be: 220-240 V, 50-60 Hz and the supply line must be protected by an efficient grounding link and is equipped with a bipolar switch with differential thermal 0.03 A safety.

For safety reasons it's essential to leave the film applied on top of the glass to avoid the fall of dangerous pieces of glass in case of breakage. Cut only the area affected by the projection beam.

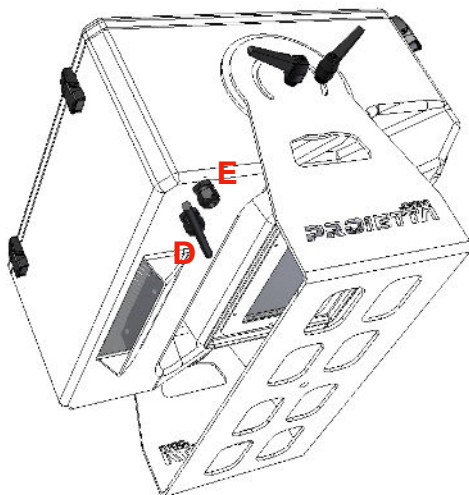
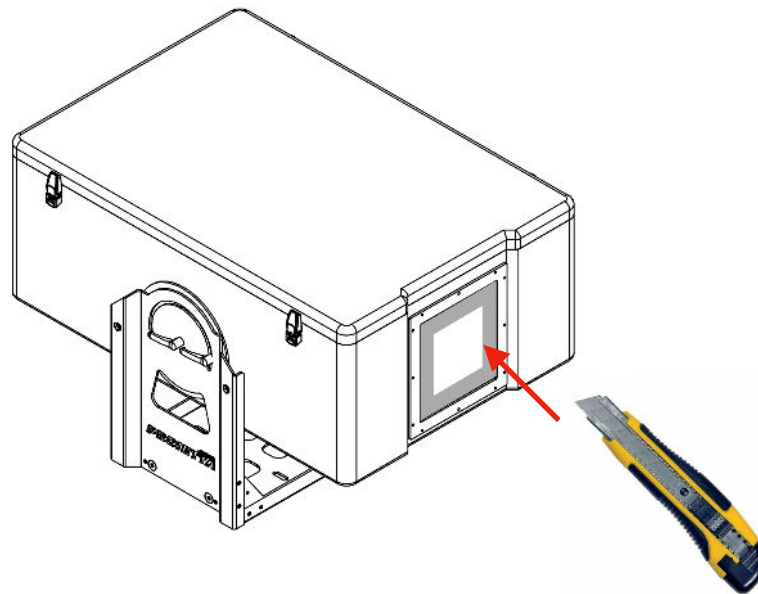

D) Power cable for main outlet included.

E) Sealed input for signal cables (hdmi/audio/ ethernet).



**CABLE INPUT BELOW THE CASE**  
Place the signal cables in the appropriate input below the case and make sure to establish the press to prevent water from entering



## FIXING THE VIDEO PROJECTOR

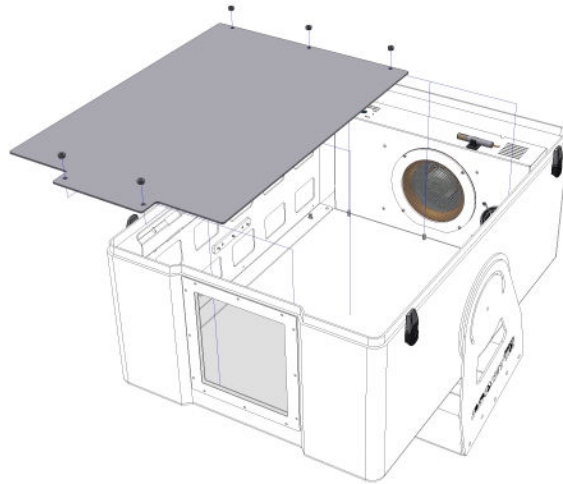

Take as a reference the video projector fastening holes by helping with the semi-transparent paper; mark the placement of the holes in the projector screws.

Remove Plate A from the main one, mark the holes onto plate A from the paper and drill according to the diameter of the screws of your video projector.

On the opposite side of Plate A use a countersink (1) to create a hole to insert a flat-headed conical screw.

Attach the video projector to Plate A using the appropriate screws (2) for your video projector (choose flat conical head screws) and insert both into the case.

1



2



# MAINTENANCE

## FILTERS AND SEALS

It's important to keep the intake filter clean for good ventilation, otherwise it may be inefficient and as a result the lamp may last less than stated and the projector may get damaged or stop working unexpectedly.

Clean the filters frequently, their replacement depends on the environment in which the protective case is placed.

## REMOVING FILTERS:

Unscrew the frame to remove filters

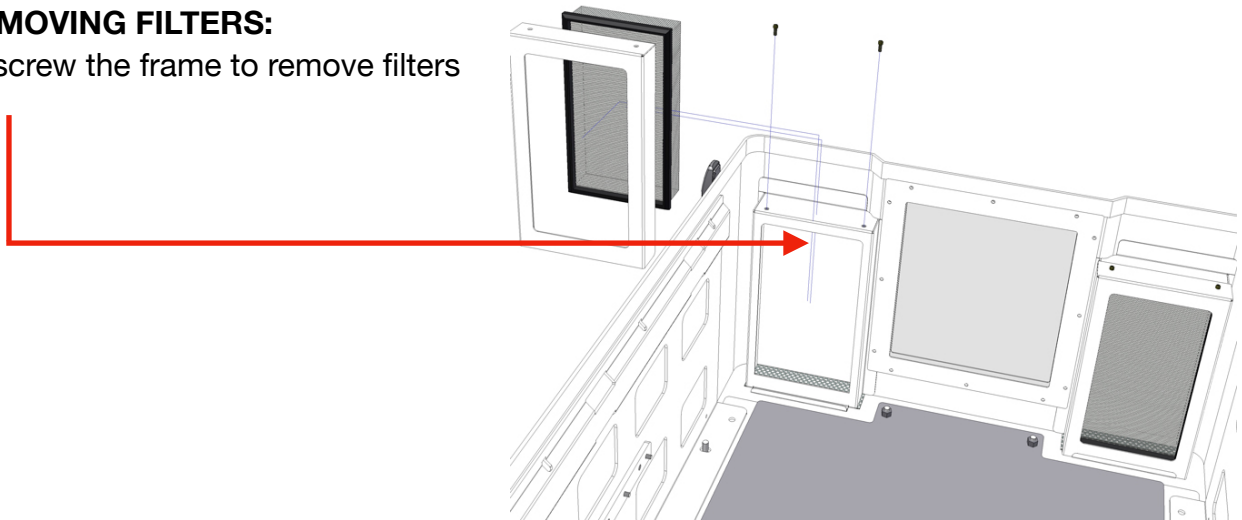

Check the seals regularly.

If the seals are damaged, do not use the protective case because the water could enter inside the case and damage the video projector causing an electric shock.

Contact the Proietta Support for any spare parts: [www.proietta.com](http://www.proietta.com).

# CAUSE AND SOLUTIONS OF POSSIBLE PROBLEMS

## VENTILATION SYSTEM

To test the ventilation system, heat the probe A (see the first picture) to act on the operation of the fan.

## HEATING SYSTEM

The product has a heating system that keeps the temperature at least 5°C inside the protective case even when the projector is turned off.

To test it, it's necessary to point compressed air about 5 cm of distance from the B probe (see the second picture). Then the second fan will act by emitting hot air, otherwise do not use the product on days with temperatures below 5°C (41°F).

Both operating signals can be monitored by the application provided by Proietta under the heading Status. You should contact the Proietta Support in case you have the following error messages:

- TC INT ERROR (internal temperature sensor anomaly)
- TC EXT ERROR (external temperature sensor anomaly)

Other messages that can be reported in Status:

- OK-RUN the device is working properly
- LOW CPU VOLTAGE
- HIGH CPU VOLTAGE
- HUMIDITY ERROR (humidity sensor anomaly)
- TC INT ERROR (internal temperature sensor anomaly)
- TC EXT ERROR (external temperature sensor anomaly)

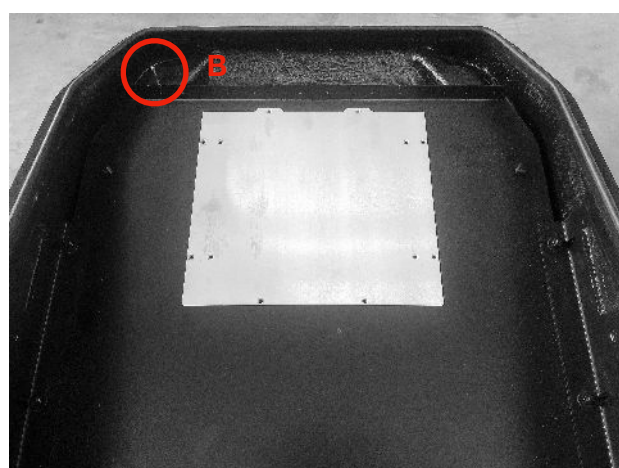
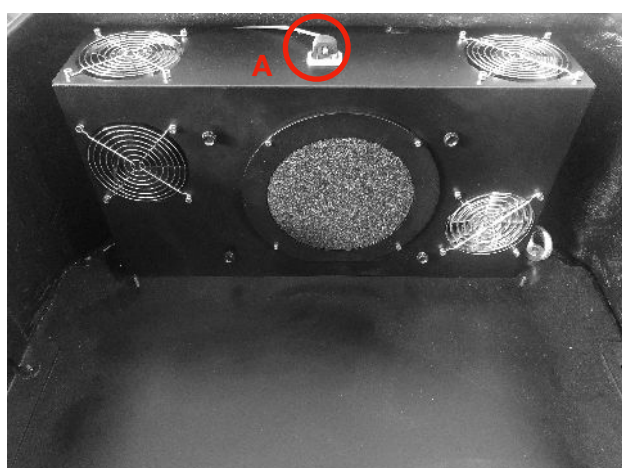

# PROIETTA APP INSTALLATION

- 1) Download the application from Apple Store o Google Play by typing PROIETTA Exterior Projector.
- 2) When the installation is complete, open the app and allow location services on your device.
- 3) Select LISTED PAIRED DEVICE and, among the different bluetooth connection options, choose the one that coincides with the serial number of the PROIETTA product that you want to monitor.  
e.g. 25K20200502
- 4) Confirmed the request for association between app and product enter the PIN that coincides with the last 6 numbers of the serial.  
e.g. 25K20**200502**
- 5) When you open the main screen to monitor your product, a flashing red dot in the top right of the screen confirms that you have paired it with the app.

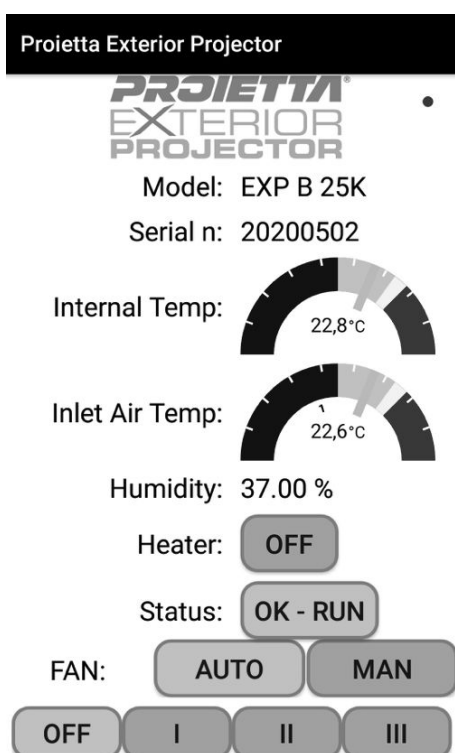

**Model**

**Serial Number**

**Temperature inside the case**

**Incoming Temperature**

**Humidity**

**Heating Status (ON-OFF)**

**Status:** reports any error

**Fan** can work in automatic or manual mode

**AUTO** automatic speed of the fans.

I,II,III report at what speed the fans are working at.

If you need to adjust the fan speed manually: set the **MAN** mode. The starting speed will be maximum and you can go down in speed, but without going below the minimum provided by the board in the conditions of use.

## BLUETOOTH BOARD (STANDARD)

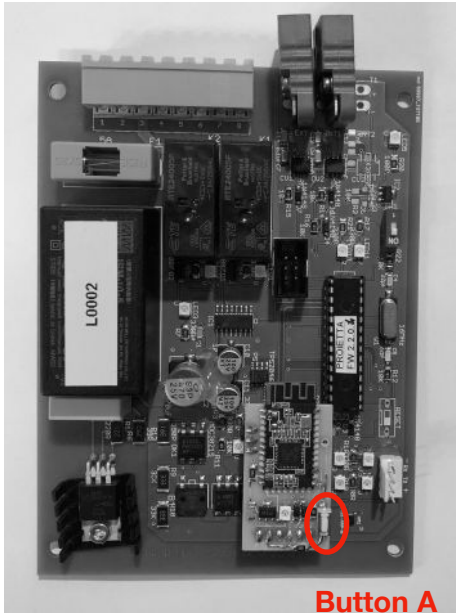

**Reset the Bluetooth Module PIN** —> Push Button A

To reset the PIN press the button, indicated with the red circle on the Bluetooth module, for at least 2 seconds and the PIN becomes: 0000000.

## ETHERNET BOARD (ON REQUEST)

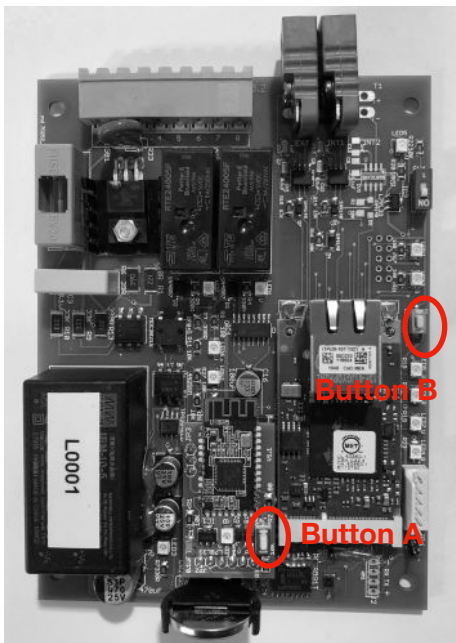

**Reset the Bluetooth Module PIN** —> Push Button A

To reset the PIN press the button, indicated with the red circle on the Bluetooth module, for at least 2 seconds and the PIN becomes: 0000000.

**Reboot/Reset to Factory** —> Push Button B

Hold the button down for two seconds until a red led lights up. By stopping pressing the board restarts (Reboot) and the led shuts down again.

Holding down the button for 10 seconds the led turns off and when it is re-lighting, the board will be formatted to the factory settings (**Reset to Factory**).

Reset to Factory resets the board account and IP to the default network parameters.

## Configuring the case's network address relative to your network (access from LAN)

The network address must be configured based on the parameters of your network by typing IP and password.

### DEFAULT NETWORK PARAMETERS

IP: 192.168.1.233

NET MASK: 255.255.255.0

GATEWAY: 192.168.1.1

To connect to the network adapter for configuration, it is necessary to have a computer with an address in the range 1 to 254 excluding 233.

Open a browser and type the address of the board (IP: 192.168.1.233) (1)

When prompted for a username and password use for read-only:  
username: user  
password: user

The credentials for the configuration are:  
username: admin  
password: admin

To configure the network address of the protective case to your network you have to select "Configuration" (2).

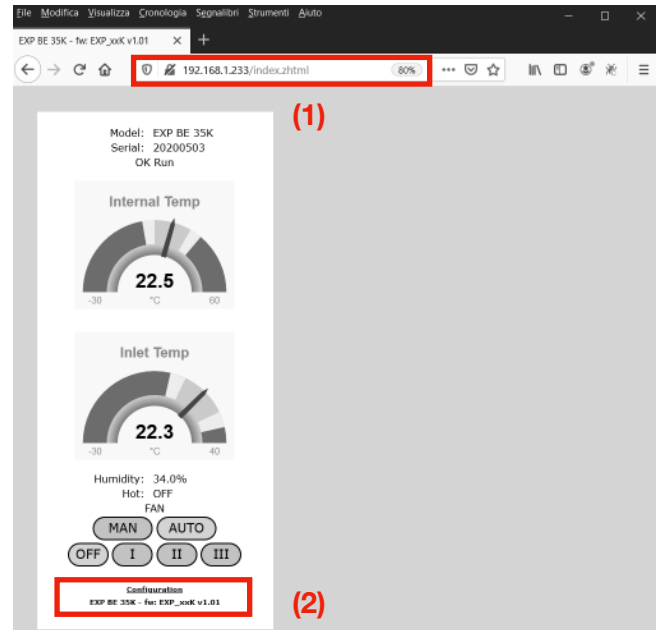

Enter your network parameters (3).

**Server IoT** should not be modified.

**Time Int** time interval between the publishing of the informations about the status of the case and the next one (default 1s, but it can be modified in a time interval between 1s and 300s).

In **Maintenance**, you can do the Reboot and Reset to Factory directly from the app.

In **Account**, you can change the user name and password for read-only or configuration mode.

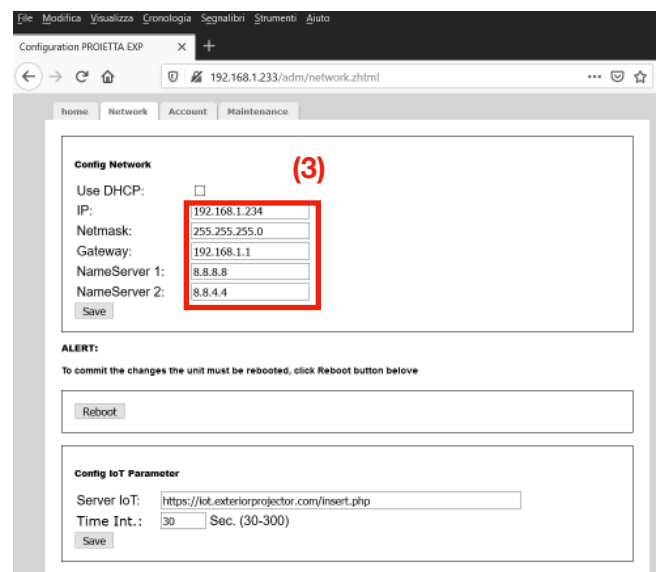

# PROIETTA CONTROL BOARD (LED SIGNALLING OPERATION)

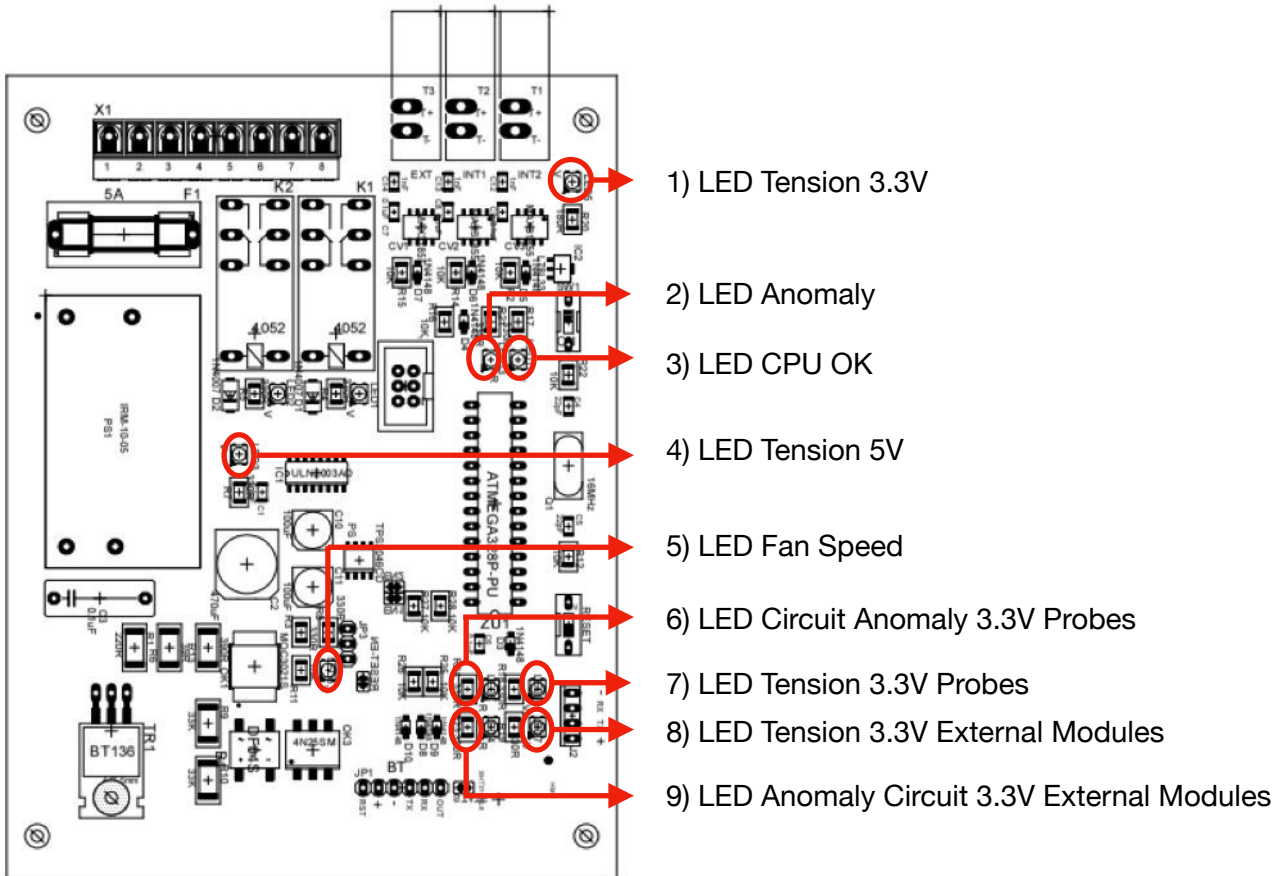

## LED 1

Green LED reports the presence of 3.3V voltage for the power of the probes.

## LED 2

Red LED reports an anomaly by flashing:

- a slow flash → Low CPU voltage
- two slow flashes → High CPU voltage
- a fast flash → External TC probe error
- two fast flashes → Error probe TC Internal
- three fast flashes → Error probe Humidity

## LED 3

Green LED reports how the CPU works:

- a flash → control board set for mode without external probe
- two flashes → control board set for mode with external probe

## LED 4

Green LED reports the presence of 5V voltage for the power of the board.

### LED 5

Green LED reports the speed of the air extraction fan:

- a flash → speed I
- two flashes → speed II
- three flashes → speed III

### LED 6

Red LED reports a malfunction of 3.3V voltage for the power supply of the probes.

### LED 7

Green LED reports the presence of 3.3V voltage for the power supply of the probes.

### LED 8

Green LED reports the presence of 3.3V voltage for the power supply of the external modules (e.g. Bluetooth).

### LED 9

Red LED reports a malfunction of 3.3V voltage for the power supply of the external modules (e.g. Bluetooth).

## SWITCH FOR THE BOARD CONFIGURATION

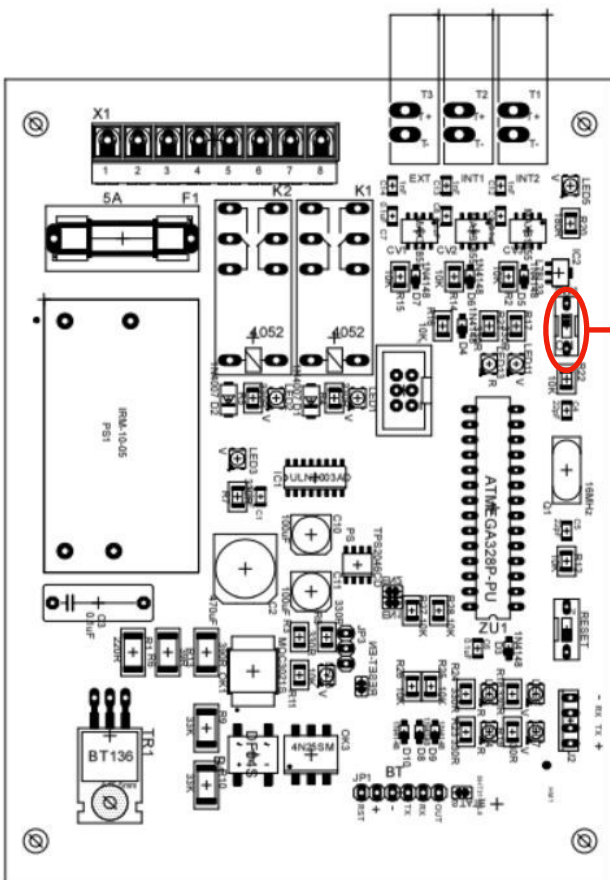

Configuration switch

External probe mode configuration switch

Placing the stick on 1 you activate the mode without external probe



# WARRANTY

The product is covered by warranty under the terms of the law (24 months). In case of malfunction during the warranty period, the product will be repaired or replaced at the discretion of the manufacturer.

The following informations are required for the use of the warranty:

- Purchase date (the invoice date is valid)
- Detailed description of the issue.

It is essential to follow the safety instructions and warnings contained in this manual.

Any damage caused by non-compliance with the manual causes the warranty to expire.

The manufacturer does not take any responsibility for damages or problems caused by non-compliance with the manual.

The only maintenance operation allowed in warranty is the replacement of the filters. Any other repairs must be carried out solely by the manufacturer, who denies any responsibility for unauthorized interventions.

## DECLARATION OF CONFORMITY

The product to which this manual refers is in accordance with the Directives of the European Community. The examination is made clear by the application of the CE mark on the product and the declaration of compliance.

The device meets the requirements of the 2002/95/CE (RoHS) Directive; the General Safety Information Regulations: EN60598-1, EN60598-2-17 and the European Parliament's Directive 2004/108/EC on Electromagnetic Compatibility.



## DISPOSAL OF UNUSED PRODUCT

The device must be disposed of in accordance with the applicable laws relating to lighting products. In any case, it should not be thrown between normal waste or dispersed in the environment, the latter action, although legally pursued, is a serious danger to animals and people and a source of long-term pollution. The product cannot be treated as a simple urban waste and must be disposed of appropriately in accordance with existing waste disposal regulations.



Avigliana, 09/11/2019

A handwritten signature in black ink, appearing to read 'Proietta'.

**PROIETTA** srl

Viale Dei Mareschi 4/d - 10051 - Avigliana - TO (Italy) - VAT number: IT09964950019  
tel. +39 011 9761039, [info@proietta.com](mailto:info@proietta.com), [www.proietta.com](http://www.proietta.com)